

INSTRUCTIONS FOR KIT #2405570 DUAL KIT—stainless steel

FITS 2004-2005 FULL-SIZE DODGE 1/2 TON RAM W/5.7L V8 HEMI ONLY, 2WD & 4WD, ALL WHEEL BASES, DOES NOT FIT DIESEL, V6, 5.9L OR 4.7L, AND V-10.

NOTE: DO NOT TIGHTEN ANY CLAMPS OR BOLTS UNTIL THE LAST STEP!

- 1) REMOVE THE EXHAUST SYSTEM AT THE CLAMP AT THE MUFFLER LEAVING ONLY THE ORIGINAL Y PIPE, RUBBER MOUNTS, CATALYTIC CONVERTER, AND O.E. EXTENSION PIPE ON THE TRUCK. YOU MAY NEED TO USE A LUBRICANT TO REMOVE THE WIRE HANGERS FROM THE O.E. RUBBER MOUNTS.
- 2) THE FRONT EXTENSION PIPE WILL FIT ALL WHEEL BASE TRUCKS WITHOUT CUTTING. USE A 2-3/4" CLAMP TO ATTACH THE EXTENSION PIPE TO THE O.E. EXTENSION PIPE, BE SURE TO LINE UP THE NOTCH. (THE EXTENSION PIPE WILL SHIFT THE EXHAUST AWAY FROM THE DRIVE SHAFT).
- 3) USE A 3" MUFFLER CLAMP TO ATTACH THE INLET OF THE MUFFLER AND THE FRONT EXTENSION PIPE TOGETHER.
- 4) INSTALL THE LEFT TAIL PIPE (4 BENDS) USING THE LEFT 2-1/2" HANGER CLAMP (SHORTER) TO THE LEFT OUTLET OF THE MUFFLER. CONNECT THE WIRE PORTION OF THE HANGER TO THE O.E. RUBBER MOUNT ABOVE THIS CONNECTING POINT.
- 5) INSTALL THE LEFT TAIL PIPE EXTENSION (42-1/2") TO THE LEFT TAIL PIPE USING A 2-1/2" CLAMP.
- 6) LOCATE OR DRILL A HOLE IN THE FRAME NEAR THE MIDDLE OF THE LEFT TAIL PIPE EXTENSION. (THERE IS A LARGE 1" WIDE HOLE THAT IS IDEAL TO USE). USING THE 3/8" X 3-1/2" BOLT, NUT, LOCK, FENDER AND LARGE WASHER (INSTALL THE SMALLER FENDER WASHER TO THE BOLT FIRST, THEN INSTALL THE LARGER WASHER), INSTALL THE BR91930 (360 SWINGER HANGER) TO THE FRAME AND ATTACH TO THE LEFT TAIL PIPE EXTENSION USING A 2-1/2" CLAMP.
- 7) INSTALL THE RIGHT TAIL PIPE (5 BENDS) USING THE RIGHT 2-1/2" HANGER CLAMP (LONGER) TO THE RIGHT OUTLET OF THE MUFFLER. CONNECT THE WIRE PORTION OF THE HANGER TO THE O.E. RUBBER MOUNT ABOVE THIS CONNECTING POINT.
- 8) LOCATE OR DRILL A HOLE IN THE FRAME NEAR THE CONNECTING POINT OF THE RIGHT TAIL PIPE AND THE RIGHT TAIL PIPE EXTENSION (31-1/2"). (THERE IS A LARGE 1" WIDE HOLE THAT IS IDEAL TO USE). USING THE 3/8" X 3-1/2" BOLT, NUT, LOCK, FENDER AND LARGE WASHER (INSTALL THE SMALLER FENDER WASHER TO THE BOLT FIRST, THEN INSTALL THE LARGER WASHER), INSTALL THE BR91930 (360 SWINGER HANGER) TO THE FRAME AND ATTACH TO THE RIGHT TAIL PIPE AND EXTENSION USING A 2-1/2" CLAMP. YOU WILL WANT TO TRIM BOTH OF THE EXTENSIONS TO YOUR DESIRED LENGTH. INSTALL THE STAINLESS STEEL TIPS TO THE TAIL PIPES USING THE REMAINING 2-1/2" CLAMPS.
- 9) TIGHTEN ALL CLAMPS AND BOLTS AND CHECK FOR CLEARANCE OF THE FRAME, BODY, AND BRAKE AND FUEL LINES.

HARDWARE KIT FOR KIT #2405570:

- 6) 2-1/2" CLAMPS stainless steel
- 1) 3" CLAMP stainless steel
- 1) LEFT 2-1/2" HANGER CLAMP-# 2968ss
- 1) RIGHT 2-1/2" HANGER CLAMP-#2967ss
- 2) 360 SWINGER HANGER-BR91930
- 2) 3/8" X 3-1/2" BOLTS stainless steel
- 2) 3/8" NUTS stainless steel
- 2) #33012 1/2" LARGE WASHERS stainless steel
- 2) #33219 3/8" FENDER WASHERS stainless steel
- 2) 3/8" LOCK WASHERS stainless steel
- 1) 2-3/4" CLAMP
- 1) FRONT EXTENSION PIPE #2405571
- 1) LEFT TAIL PIPE #2405027
- 1) RIGHT TAIL PIPE #2405028
- 1) LEFT TAIL PIPE EXT (42-1/2" LONG)-2405573
- 1) MUFFLER # 458442
- 1) RT TAIL PIPE EXTENSION (31-1/2" LONG)-2405572
- 2) 9363009 stainless steel tips

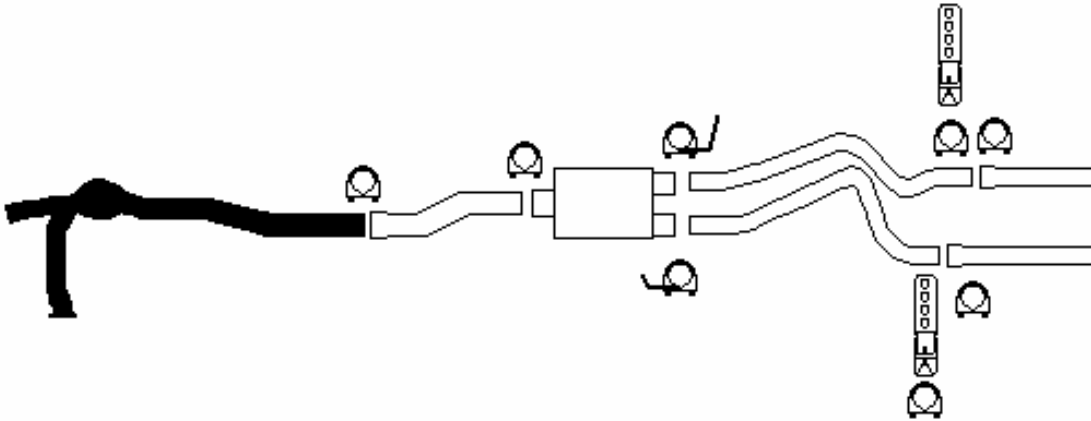

DANGER WARNING: SHOULD THE PURCHASER DECIDE TO INSTALL THIS, OR ANY OTHER EXHAUST PRODUCT AT HOME, BE WARNED THAT PLEASURE CAR OR LIGHT DUTY TRUCK/VAN "BUMPER JACKS" ARE INTENDED FOR EMERGENCY USE ONLY. THE USE OF FRAME CONTACT JACK STANDS IN CONJUNCTION WITH A FLOOR JACK AS MAIN SUPPORT IS HIGHLY RECOMMENDED TO MINIMIZE ACCIDENTAL DROPPING OF A VEHICLE WHILE THE INSTALLATION PROCEEDS.

Limitation of liability--Disclaimers: The regulation of emissions production, noise levels and safety standards is undertaken by the federal government, each of the fifty state legislatures, and by many local municipalities, towns and counties.

The manufacturer makes no warranties of merchantability, of fitness for a particular purpose, or that its products are approved for general use, or that its products comply with laws, regulations or ordinances in the states where they may be sold to the ultimate purchaser, the consumer.

The entire risk as to the conformity of this product in any such state and as to repair, should the product prove to be defective or non-conforming, is on the retail purchaser, the buyer, the ultimate consumer of such product and it is not upon the seller, distributor, or manufacturer.

In this connection, retail purchaser, the buyer, the ultimate consumer assumes the burden of the entire cost of any and all necessary service, alterations, and or repair.

The foregoing statement limits the liability of the manufacturer.



Heartthrob Exhaust--Litchfield, Mn

For detailed digital installation pictures, email us at mike@heartthrobexhaust.com

www.heartthrobexhaust.com

320-693-0222

BUILD SHEET FOR: 2-1/2" SPLIT REAR DUAL KITS

PART#: 2405570 **s/s dual kit**

- ___ 1) #2405571 FRONT EXTENSION PIPE
- ___ 1) #458442 MUFFLER, 3" IN/DUAL 2-1/2" OUT
- ___ 1) #2405027 LEFT TAIL PIPE
- ___ 1) #2405028 RIGHT TAIL PIPE
- ___ 1) LEFT TAIL PIPE EXT.-42-1/2" LONG-2405573
- ___ 1) RT TAIL PIPE EXT.-31-1/2" LONG-2405572
- ___ 2) 9363009 stainless steel tips
- ___ 1) HARDWARE KIT

INSPECTED BY: _____

DATE: _____

INSPECTED BY: _____

DATE: _____

BUILD SHEET FOR: 2-1/2" SPLIT REAR DUAL KITS

PART#: 2405570 **s/s dual kit**

- ___ 1) #2405571 FRONT EXTENSION PIPE
- ___ 1) #458442 MUFFLER, 3" IN/DUAL 2-1/2" OUT
- ___ 1) #2405027 LEFT TAIL PIPE
- ___ 1) #2405028 RIGHT TAIL PIPE
- ___ 1) LEFT TAIL PIPE EXT.-42-1/2" LONG-2405573
- ___ 1) RT TAIL PIPE EXT.-31-1/2" LONG-2405572
- ___ 2) 9363009 stainless steel tips
- ___ 1) HARDWARE KIT

INSPECTED BY: _____

DATE: _____

INSPECTED BY: _____

DATE: _____