

## KIT #8158670

This kit fits '67-'81 Camaro V8, '75 Buick Apollo V8, '75-'79 Buick Skylark V8, '67-'81 Firebird V8, '62-'79 Nova/Chevy II V8, '73-'79 Omega V8, '72-'79 Phoenix & Ventura V8, all with standard headers and with 3" collectors at the headers.

**NOTE:** THE CATALYTIC CONVERTERS ARE NOT SUPPLIED WITH THIS EXHAUST SYSTEM. THIS SYSTEM IS NOT LEGAL FOR ON-ROAD USE ON VEHICLES THAT ORIGINALLY WERE EQUIPPED WITH A CATALYTIC CONVERTER.

**NOTE:** THE HEADERS AND MUFFLERS ARE NOT INCLUDED IN THIS KIT!!

**DANGER WARNING:** SHOULD THE PURCHASER DECIDE TO INSTALL THIS EXHAUST PRODUCT AT HOME, BE WARNED THAT PLEASURE CAR OR LIGHT DUTY TRUCK/VAN "BUMPER" JACKS ARE INTENDED FOR EMERGENCY USE ONLY. THE USE OF FRAME CONTACT JACK STANDS IN CONJUNCTION WITH A FLOOR JACK AS MAIN SUPPORT IS HIGHLY RECOMMENDED TO MINIMIZE ACCIDENTAL DROPPING OF A VEHICLE WHILE THE INSTALLATION PROCEEDS.

### HARDWARE KIT:

- |                                  |  |
|----------------------------------|--|
| 4) ST4 HANGERS                   | 1) LEFT COLLECTOR PIPE #124EE-3                |
| 4) SNAPPER GROMMETS              | 1) RIGHT COLLECTOR PIPE #124EE-3               |
| 4) 5/16" X 1" LAG SCREWS         | 2) LEFT & RIGHT FRONT EXTENSION PIPES #124EE-4 |
| 8) 2-1/2" CLAMPS                 | 1) LEFT TAIL PIPE #2250014                     |
| 2) F33 FLANGES                   | 1) RIGHT TAIL PIPE #2250004                    |
| 6) 3/8" NUTS                     |  |
| 6) 3/8" LOCKWASHERS              |  |
| 6) 3/8" X 1-1/4" BOLTS           |  |
| 2) #MP48005 3" COLLECTOR GASKETS |  |

HANGER CONSISTS OF A METAL STRAP, GROMMETS, HARDWARE, AND CLAMP (SEE ILLUSTRATION).

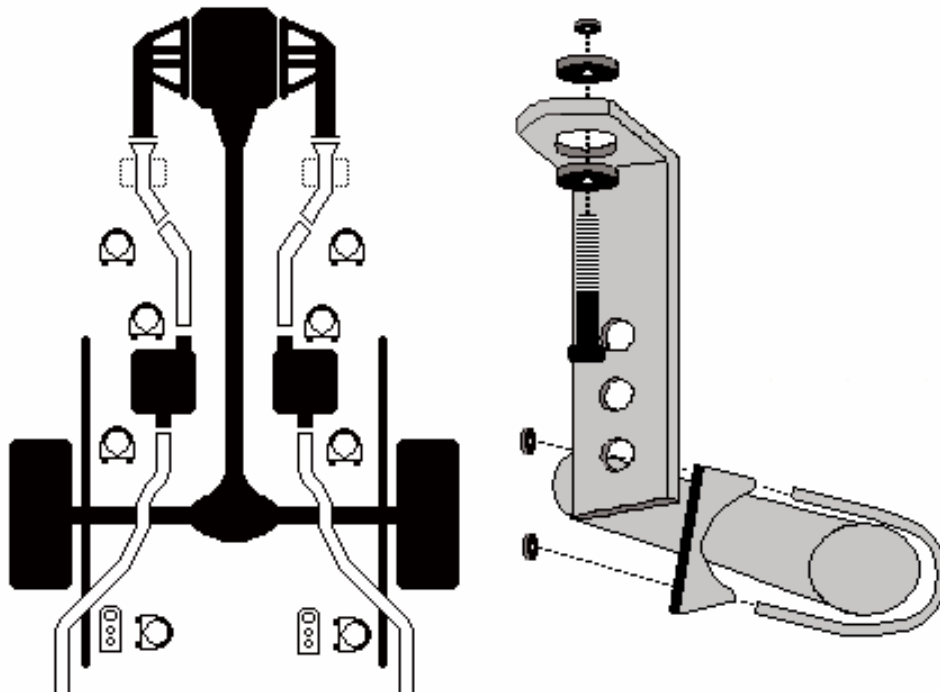

**KIT #8158670**

**INSTALLATION INSTRUCTIONS:**

NOTE: DO NOT TIGHTEN ANY CLAMPS OR NUTS UNTIL THE LAST STEP!!

- 1) REMOVE THE OLD EXHAUST SYSTEM AFTER THE HEADERS. REMOVE THE OLD HANGERS AND BRACKETS.
- 2) INSTALL THE LEFT AND RIGHT COLLECTOR PIPES USING THE MP48005 GASKETS AND F33 FLANGES. TIGHTEN ONLY ENOUGH TO HOLD IN PLACE, USING THE 3/8" X 1-1/4" BOLTS AND NUTS. **NOTE:** FOR VEHICLES REQUIRING CATALYTIC CONVERTERS TO MEET EPA GUIDELINES, CATALYTIC CONVERTER #73-7774 OR EQUIVALENT SHOULD BE INSTALLED ON THE HEADER COLLECTOR PIPES AFTER THE HEADER COLLECTORS ON THE COLLECTOR PIPES.
- 3) INSTALL THE LEFT AND RIGHT FRONT EXTENSION PIPES TO THE COLLECTOR PIPES USING 2-1/2" CLAMPS. BE SURE TO LEAVE ADEQUATE CLEARANCE BETWEEN THE FLOOR BOARDS AND THE DRIVE SHAFT. **NOTE:** THE EXTENSION PIPES MAY BE SHORTENED TO FIT VARIOUS HEADER DESIGNS OR DIFFERENT LENGTH MUFFLERS.
- 4) INSTALL THE MUFFLERS (NOT INCLUDED, OFFSET IN/CENTER OUT) ONTO THE FRONT EXTENSION PIPES USING 2-1/2" CLAMPS. ROTATE THE FRONT EXTENSION PIPES TO CLEAR THE DRIVESHAFT, AND FRAME, AND GENERAL CLEARANCE.
- 5) MOUNT THE HANGER BRACKETS TO THE EXISTING HOLES IN THE FRAME BEHIND THE REAR AXLE USING THE LAG SCREWS AND THE SNAPPER GROMMET (SEE DRAWING). THE HANGERS SHOULD BE INSTALLED TO THE TAIL PIPES AT WHERE THE TAIL PIPES CROSS UNDER THE FRAME. TWO ADDITIONAL HANGERS HAVE BEEN INCLUDED TO USE AT YOUR PREFERRED LOCATION.
- 6) INSTALL THE LEFT AND RIGHT TAIL PIPES TO THE MUFFLERS USING 2-1/2" CLAMPS. USE A 2-1/2" CLAMP TO CONNECT THE PIPES AND A HANGER.
- 7) MAKE SURE THAT ALL THE PARTS OF THE SYSTEM ARE CLEAR OF FRAME MEMBERS, ALL HOSES, SUSPENSION, AND BRAKE AND FUEL LINES. STARTING AT THE COLLECTOR PIPES, TIGHTEN ALL CONNECTIONS AND NUTS. MAKE SURE ALL PARTS ARE CLEAR AND WILL NOT LEAK OR RATTLE. AFTER SEVERAL DAYS OF DRIVING RETIGHTEN ALL BOLTS.

LIMITATION OF LIABILITY-DISCLAIMERS: THE REGULATION OF EMISSIONS PRODUCTION, NOISE LEVELS AND SAFETY STANDARDS IS UNDERTAKEN BY THE FEDERAL GOVERNMENT, EACH OF THE FIFTY STATE LEGISLATURES, AND BY MANY LOCAL MUNICIPALITIES, TOWNS AND COUNTIES.

THE MANUFACTURER MAKES NO WARRANTIES OF MERCHANTABILITY, OF FITNESS FOR A PARTICULAR PURPOSE, OR THAT ITS PRODUCTS ARE APPROVED FOR GENERAL USE, OR THAT ITS PRODUCTS COMPLY WITH LAWS, REGULATIONS OR ORDINANCES IN THE STATES WHERE THEY MAY BE SOLD TO THE ULTIMATE PURCHASER, THE CONSUMER.

THE ENTIRE RISK AS TO THE CONFORMITY OF THIS PRODUCT IN ANY SUCH STATE AND AS TO REPAIR, SHOULD THE PRODUCT PROVE TO BE DEFECTIVE OR NON-CONFORMING, IS ON THE RETAIL PURCHASER, THE BUYER, THE ULTIMATE CONSUMER, OF SUCH PRODUCT AND IT IS NOT UPON THE SELLER, DISTRIBUTOR, OR MANUFACTURER.

IN THIS CONNECTION, THE RETAIL PURCHASER, THE BUYER, THE ULTIMATE CONSUMER ASSUMES THE BURDEN OF THE ENTIRE COST OF ANY AND ALL NECESSARY SERVICE, ALTERATIONS AND OR REPAIR.

THE FOREGOING STATEMENT LIMITS THE LIABILITY OF THE MANUFACTURER.

CALIFORNIA VEHICLE CODE SECTION 27156 PROHIBITS THE ADVERTISING, OFFERING FOR SALE, OR INSTALLATION OF ANY DEVICE WHICH MODIFIES A VEHICLE'S EMISSION CONTROL SYSTEM. THIS PRODUCT IS THEREFORE NOT LEGAL FOR SALE OR USE IN CALIFORNIA ON VEHICLES EQUIPPED WITH CATALYTIC CONVERTERS.



Heartthrob exhaust systems are manufactured by Heartthrob Exhaust--Litchfield, MN

Email us at [mike@heartthrobexhaust.com](mailto:mike@heartthrobexhaust.com) with any questions.

**BUILD SHEET FOR: HEADER DUAL KIT**

PART #'S: 8158670

- \_\_\_\_\_ 1) LEFT COLLECTOR PIPE#124EE-3
- \_\_\_\_\_ 1) RIGHT COLLECTOR PIPE#124EE-3
- \_\_\_\_\_ 2) LEFT & RIGHT FRONT EXTENSION PIPES#124EE-4
- \_\_\_\_\_ 1) LEFT TAIL PIPE#2250014
- \_\_\_\_\_ 1) RIGHT TAIL PIPE#2250004
- \_\_\_\_\_ 1) HARDWARE KIT

INSPECTED BY: \_\_\_\_\_

DATE: \_\_\_\_\_

INSPECTED BY: \_\_\_\_\_

DATE: \_\_\_\_\_

**BUILD SHEET FOR: HEADER DUAL KIT**

PART #'S: 8158670

- \_\_\_\_\_ 1) LEFT COLLECTOR PIPE#124EE-3
- \_\_\_\_\_ 1) RIGHT COLLECTOR PIPE#124EE-3
- \_\_\_\_\_ 2) LEFT & RIGHT FRONT EXTENSION PIPES#124EE-4
- \_\_\_\_\_ 1) LEFT TAIL PIPE#2250014
- \_\_\_\_\_ 1) RIGHT TAIL PIPE#2250004
- \_\_\_\_\_ 1) HARDWARE KIT

INSPECTED BY: \_\_\_\_\_

DATE: \_\_\_\_\_

INSPECTED BY: \_\_\_\_\_

DATE: \_\_\_\_\_